

DATA LOGGERS

HYGROLOG SERIES

The long term recording of humidity and temperature conditions is very important in storage, shipping, production processes, test facilities and many other areas. Once logged, the temperature and humidity data can be evaluated statistically. This provides valuable information on conditions that can have an influence on people, materials and objects.

The ROTRONIC data loggers fulfil the requirements of FDA 21 CFR Part 11 and GAMP 4. They have a degree of functionality currently not achieved by any other logger while being highly accurate and easy to use. Data can be shown in graph or table form. A large range of interchangeable probes means simple maintenance and flexibility in different applications, and loggers are available in a range configurations to suit most uses.

Applications

Warehouses, museums, libraries, art galleries, clean rooms, server rooms, factories, shipping, residential properties

Highlights

- Flash card data memory
- Saves up to 47,000 data records per MB card storage capacity
- Data retrievable by card reader, PDA, PC with HW4 or docking station
- Real-time clock
- Logging interval selectable between 5 s and 24 h
- Battery or rechargeable battery operation
- Battery life more than 1 year
(depending on rechargeable battery and options)
- Logging mode selectable: start/stop, text/protected mode
- Logger electronics operating range:
0...100 %rh; -30...70 °C; with display -10...60 °C
- LED status indicator and audible alarm (beep tone)
- Optional display and keypad for display of measured values, status display, operation, adjustment and to view the log data
- Networkable with optional docking station
- Can be used with all HygroClip HC2-xx probes
(see the chapter on probes, pages 6-12)



HYGROLOG NT2

Order code HL-NT2

- Logger for interchangeable HC2-xx probes (order probes separately)
- 9 V battery
- Logger operating range: 0...100 %rh; -30 ...70 °C; with display -10...60 °C
- Measurement range 0...100%rh, -100...200 °C (probe dependent)
- 32 MB flash card
- Conforms to FDA 21 CFR Part 11 and GAMP4

HYGROLOG NT2-D

Order code HL-NT2-D

- Same specifications as HL-NT2, but with integrated keypad & LC display

HYGROLOG NT2-P

Order code HL-NT2-P

- As HL-NT2, but including a pre-fitted HC2-S probe

HYGROLOG NT2-DP

Order code HL-NT2-DP

- As HL-NT2-D, but including a pre-fitted HC2-S probe



For accessories and options for all Hygrolog HL-NT loggers: see pages 51/52

HYGROLOG NT3

The HygroLog NT3 models are especially suitable for changing measurement tasks. It is possible to directly connect two external probes, thereby opening up numerous possibilities where compact loggers with internal probes do not suffice. They are simple to use and easy to maintain; if probes have to be calibrated or replaced, this can be done in a few seconds without having to open the logger.

Applications

Warehouses, museums, libraries, art galleries, clean rooms, server rooms, factories, shipping, residential properties

Highlights

- Interchangeable probes, one integrated and up to two external
- Saves up to 47,000 data records per MB card storage capacity
- Data retrievable by card reader, PDA, PC with HW4 and docking station
- Real-time clock
- Logging interval selectable between 5 s and 24 h
- Battery life more than 1 year
(depending on rechargeable battery and options)
- Logging mode selectable: start/stop, text/protected mode
- Logger operating range: 0...100 %rh; -30 ...70 °C; with display --10...60 °C
- LED status indicator and audible alarm (beep tone)
- Optional display and keypad for display of measured values, status display, operation, adjustment and to view the log data
- Networkable with optional docking station
- Can be used with all HygroClip HC2-xx probes (see the chapter on probes)



HYGROLOG NT3

Order code HL-NT3

- Logger for interchangeable HC2-xx probes
- 9 V battery
- Logger operating 0...100 %rh / -10...60 °C
- Measurement range 0...100%rh, -100...200 °C (probe dependent)
- 32 MB flash card
- Conforms to FDA 21 CFR Part 11 and GAMP4
- Remote connection for second logger with display

HYGROLOG NT3-D

Order code HL-NT3-D

- As HL-NT3, with integrated keypad and LC display

HYGROLOG NT3-P

Order code HL-NT3-P

- As HL-NT3, with pre-fitted HC2-S probe

HYGROLOG NT3-DP

Order code HL-NT3-DP

- As HL-NT3-D, with pre-fitted HC2-S probe

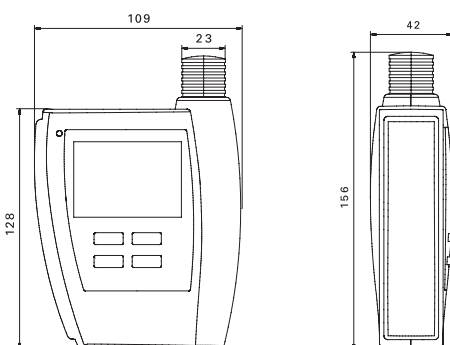

DOCKING STATIONS for HygroLog NT data loggers

The docking stations for the HygroLog NT series provide various functions depending on the model. They can serve as a mounting bracket, power supply connection, interface module for Ethernet, RS485, USB, RS232 and Wireless LAN or as an upgrade to allow additional digital or analogue probes to be connected to a logger. Probe inputs can be either digital or analog (voltage or mA). The types detailed here are not compatible with devices from earlier generations.

Overview docking stations												
Order code	Inputs					Interfaces						
	External power supply	Digital / Analog probe inputs *	Analog input 0...2.5 V	Analog input 0(4) ...20 mA	Switch inputs	Pt100 inputs	RS232 & RS485	USB & RS485	TCP/IP RJ45 & RS485	WLAN & RS485	Relay outputs	Query via Internet Explorer *
HL-DS-NT0												
HL-DS-NT1	✓											
HL-DS-NT2	✓						✓					
HL-DS-NT3	✓							✓				
HL-DS-NT4	✓				2				✓			
HL-DS-NT4-WL	✓				2					✓		
HL-DS-NT4-WEB*	✓				2							
HL-DS-PT2	✓				2	4		✓				
HL-DS-PT4	✓				2	2			✓			
HL-DS-PT4-WL	✓				2	2				✓		
HL-DS-R-1	✓				2			✓			2	
HL-U1	✓	4	✓		2		✓					
HL-U2	✓	4	✓		2			✓				
HL-U2-420	✓	4		✓	2			✓				
HL-U4	✓	4	✓		2				✓			
HL-U4-420	✓	4		✓	2				✓			
HL-U4-420-WEB*	✓	4		✓	2				✓			✓
HL-U4-WEB*	✓	4	✓		2				✓			✓
HL-U4-WEB-WL*	✓	2	✓		2					✓		✓
HL-U4-WL	✓	2	✓		2					✓		✓

* WEB: Access to data logger without HW4 software possible



DATA LOGGERS

Specifications accessories & options	
Order code	Specifications & scope of delivery
Connection sets	
Hygrodata-NT-E	PC connection set, consisting of HW4-E standard software, docking station HL-DS-NT2 and RS232 data cable
Hygrodata-NT-P	PC connection set, consisting of HW4-P professional software, docking station HL-DS-NT2 and RS232 data cable
Hygrodata-NT-E-USB	PC connection set, consisting of HW4-E standard software, docking station HL-DS-NT3 and USB data cable
Hygrodata-NT-P-USB	PC connection set, consisting of HW4-P professional software, docking station HL-DS-NT3 and USB data cable
Software	
HW4-E	Standard software for programming and data management
HW4-P	Professional software with additional validation functions
HW4-OPC	HW4-P with OPC server functionality
HW4-VAL	HW4-OPC with comprehensive validation documentation
Probe cables	
E2-F3A	Probe extension cable 30 cm for loggers with connected Ethernet docking station Use for probe 1 (internal probe) to prevent self-heating by the Ethernet module
E2-01A	Probe extension cable for HygroClip HC2 probes, 1 m, black
E3-01A	Probe extension cable for HygroClip HC2 probes, 1 m, white
E2-02A	Probe extension cable for HygroClip HC2 probes, 2 m, black
E3-02A	Probe extension cable for HygroClip HC2 probes, 2 m, white
E2-05A	Probe extension cable for HygroClip HC2 probes, 5 m, black
E3-05A	Probe extension cable for HygroClip HC2 probes, 5 m, white
E2-02A-S	Probe extension cable for HygroClip HC2 probes, 2 m, black, with short connector
E3-02A-S	Probe extension cable for HygroClip HC2 probes, 2 m, white, with short connector
Communication cables	
AC0001	Standard Ethernet patch cable, 3 m
AC0002	Standard USB A/B cable, 1.8 m
AC0004	Standard RS232 cable D-sub 9-pin, 1-8 m
AC0005	Patch cable cat. 5e UTP, 3m, crossover
AC1614-02	RS485 cable to HygroLog NT docking station, for cabling via terminal box
Signal amplifier	
AC3003	Signal amplifier set for probe-to-logger cable lengths up to 100 m, consisting of 2 connection cables with electronic amplifier, open cable ends for connection via terminal box
Power supply units	
AC1211	AC mains adapter for HygroLog NT / docking stations / 240 VAC >12 VDC
AC1213	Power supply unit 85-264 VAC/15 VDC, 100 W, DIN rail mounting
Memory cards & card reader	
AC-NT32MB	32 MB flash card, industrial type -40...85 °C
AC-NT64MB	64 MB flash card, industrial type -40...85 °C
AC0100	Multicard reader for flash cards
Other accessories	
NT-DESK	Desktop stand for HygroLog NT in combination with a docking station
ET-409	4-pin Binder connector, to connect Pt100 probes to a docking station