

HUMIDITY PROBES



HYGROCLIP2 PROBE

The HygroClip2 is a completely new type of probe in a class of its own in terms of accuracy and performance. Thanks to the new AirChip3000 technology, it also boasts a unique calibration and adjustment process as well as many other superb innovations. At the same time ROTRONIC has taken humidity measurement technology to a whole new level of performance and reliability: the HygroClip2 offers you the best possible reproducibility and a superb system accuracy of $\leq \pm 0.8\% \text{rh}$ and $\pm 0.1 \text{ K}$.

The new HygroClip2 is available in various formats: from a simple plug-in probe for handheld instruments and data loggers to the highly developed cable probes for high temperature and other special applications, we can provide you with exactly the right probe to suit your needs. As standard, they all have high accuracy, which can be increased further by specific adjustments within our patented AirChip, making every probe in our range a high-end product for all applications.

Applications

For HVAC monitoring & control, the pharmaceutical industry, building management systems, the paper industry, research, museums and many others.

Highlights

- Measures relative humidity, temperature and dew/frost point
- Records up to 2,000 measurement pairs (%rh/°C)
- Range of application 0...100 %rh / -100...200 °C (depending on probe type)
- UART interface
- Self-testing function
- Trend indication

HygroClip2 with AirChip3000 technology

- Compensates temperature and humidity at 30,000 reference points and can store 2,000 measurement pairs. If programmed by the user, it can self test and correct deviations automatically
- Freely configurable. Signal scaling, alarm limits and data logging intervals can be set by the user
- Active information and alarm generation
- Combines an ASIC (application specific integrated circuit), a microcontroller and a memory (EEPROM) on one micro-chip
- Thanks to the analog, freely scalable signal (2 x 0...1V) and the UART interface, it can be integrated not only in ROTRONIC products, but also in most OEM and customer solutions
- Can be interchanged in a few seconds without the need for readjustment
- Can be used as a reference in system qualification



STANDARD CLIMATE PROBES

Applications

HVAC, food stores, health inspection agencies, warehouse mapping, building automation systems, paper, textile and pharmaceutical industries

Use

Handheld instruments, data loggers, transmitters, OEM systems

Highlights

- Measures relative humidity, temperature and dew/frost point
- Saves up to 2,000 measurement pairs*
- Range of application 0...100 %rh / -50...100 °C
- UART interface and freely scalable analog signals 0...1 V
- Standard scaling 0...1 V = 0...100 %rh / -40...60 °C
- Probe with adjustment profile 'Standard' factory adjustment certificate



Order code	HC2-S	HC2-SH	HC2-S3	HC2-S3H
Type	Standard probe		Meteorology probe	
Material	Polycarbonate housing			
Color	Anthracite		White	
Adjustment	At 23 °C and 10, 35, 80 %rh			
Accuracy	±0.8 %rh / ±0.1 K	±0.5 %rh / ±0.1 K	±0.8 %rh / ±0.1 K	±0.5 %rh / ±0.1 K
Weight	Approx. 10 g			
Filter	Polyethylene filter included			
Sensor	Hygromer IN-1		Hygromer V-1	
Response time	<15 s		<15 s	

* Optional, requires HW4 software

Order code	HC2-R	HC2-R3
Type	Exchange/refurbished probe with new humidity sensor	
Material	Polycarbonate housing	
Color	Anthracite	White
Adjustment	At 23 °C and 10, 35, 80 %rh	
Accuracy	±0.8 %rh / ±0.1 K	
Weight	Approx. 10 g	
Filter	Polyethylene filter included	
Sensor	Hygromer IN-1	Hygromer V-1
Response time	<15 s	<15 s

* Optional, requires HW4 software

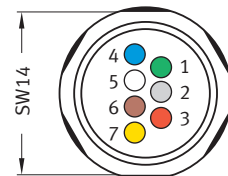
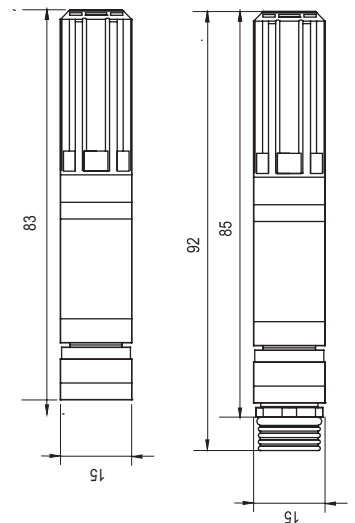

Electrical connections:
(all HygroClip2 probes with connector)

- 1 ● V+ (3.2 VDC to max. 5 VDC, ±0%; recommended: 3.3 VDC)
- 2 ● GND (ground, digital and power)
- 3 ● RXD (UART)
- 4 ● TXD (UART)
- 5 ● Analog signal %rh (0...100 %rh=0...1 V)
- 6 ● Analog signal °C (-40...60 °C = 0...1 V)
- 7 ● AGND (analog ground)

PROBES for measurements in confined spaces



Applications

Measurements in packaging and small spaces where it is not possible to work with standard probes, concrete building structures, research applications, etc.

Use

Handheld devices, data loggers, transmitters, OEM products

Highlights

- Measures relative humidity, temperature and dew/frost point
- Saves up to 2,000 measurement pairs (optional, requires HW4 software)
- Range of application 0...100 %rh / -40...85 °C
- UART interface and freely scalable analog signals 0...1 V
- Standard scaling 0...1 V = 0...100 %rh / -40...60 °C
- Probe with 'Standard' adjustment profile, factory adjustment certificate

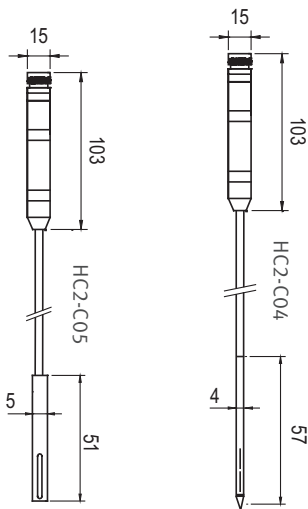

Order code	HC2-C04	HC2-C05
Type	Cable probe, Ø 4 mm, cable length ~2m	Ø 5 mm, cable length ~2m
Material	Stainless steel V2A	Brass, nickel-plated
Handle color	Anthracite	
Adjustment	At 23 °C and 10, 35, 80 %rh	
Accuracy	±1.5 %rh / ±0.3 K	
Weight	Approx. 150 g	Approx. 160 g

HIGH-TEMP. HANDHELD PROBES 15 mm

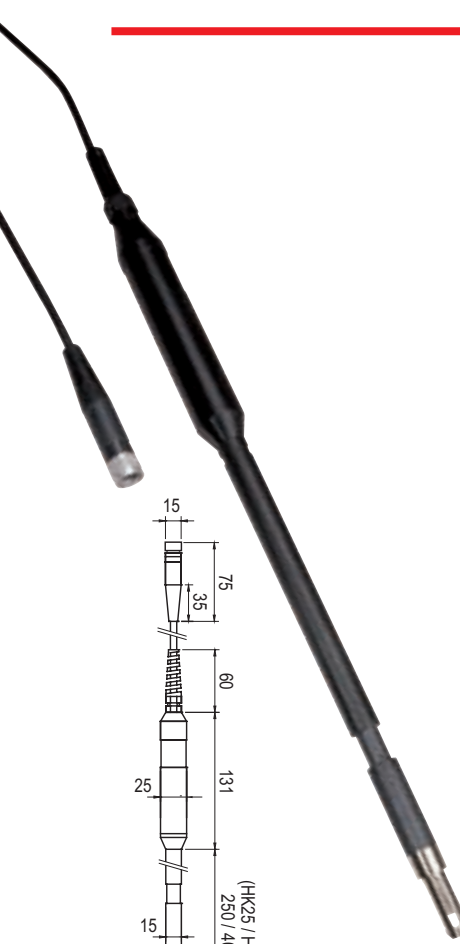

Applications

For measurements in air ducts, dryers, climatic chambers, etc. up to 200°C

Use

Handheld instruments and data loggers

Highlights

- Measures relative humidity, temperature and dew/frost point
- Saves up to 2,000 measurement pairs (optional, requires HW4 software)
- UART interface and freely scalable analog signals 0...1 V
- Standard scaling 0...1 V = 0...100 %rh / -40...60 °C
- Probe with 'Standard' adjustment profile, factory adjustment certificate

Order code	HC2-HK25	HC2-HK40
Type	Handheld probe ~2m TPU cable	
Range of appl.	0...100 %rh / -100...150 °C	0...100 %rh / -100...200 °C
Adjustment	At 23 °C and 10, 35, 80 %rh	
Accuracy	±0.8 %rh / ±0.1 K / Response time τ 63: without filter <15 s	
Probe length	250 mm	400 mm
Handle color	Anthracite	
Filter carrier	NSP-ME (order filter separately, see pages 99-100)	
Weight	Approx. 210 g	Approx. 240 g

INSERTION PROBE 5 mm, for measurements in bulk materials

Applications

Measurements in dust-free bulk materials, granules, capsules and building materials such as concrete, bricks, etc. Temperature range of application to 85 °C

Use

Handheld devices and data loggers

Highlights

- Measures relative humidity, temperature and dew/frost point
- Saves up to 2,000 measurement pairs (optional, requires HW4 software)
- Range of application 0...100 %rh / -40...85 °C
- UART interface and freely scalable analog signals 0...1 V
- Standard scaling 0...1 V = 0...100 %rh / -40...60 °C
- Probe with 'Standard' adjustment profile, factory adjustment certificate

Order code	HC2-P05
Type	∅ 5 x 200 mm, insertion probe with air slots, ~2m TPU cable
Adjustment	At 23 °C and 10, 35, 80 %rh
Accuracy	±1.5 %rh / ±0.3 K / Response time τ 63: <15 s
Handle color	Anthracite
Weight	Approx. 160 g

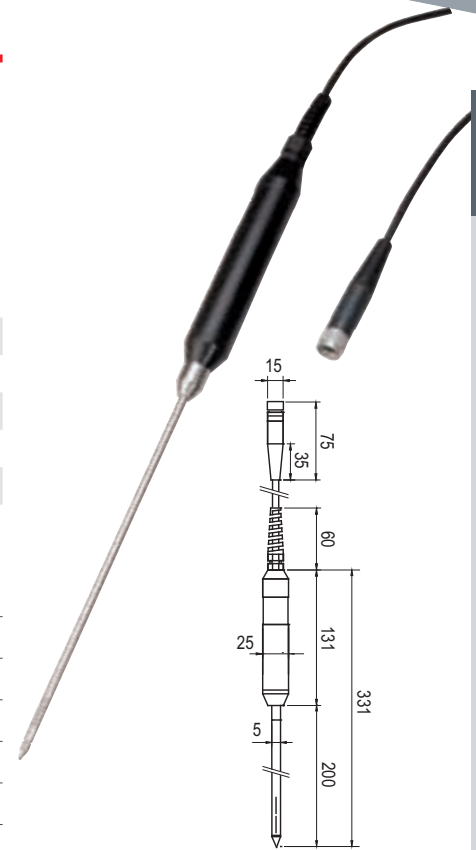

INSERTION PROBES 10 mm, for measurements in bulk materials

Applications

Measurements in dusty bulk materials such as flour, sugar and building materials such as concrete, sand etc. Temperature range of application to 85 °C

Use

Handheld devices and data loggers

Highlights

- Measures relative humidity, temperature and dew/frost point
- Saves up to 2,000 measurement pairs (optional, requires HW4 software)
- Range of application: 0...100 %rh / -40...85 °C
- UART interface and freely scalable analog signals 0...1 V
- Standard scaling 0...1 V = 0...100 %rh / -40...60 °C
- Probe with 'Standard' adjustment profile, factory adjustment certificate

Order code	HC2-HP28	HC2-HP50
Type	Insertion probe with steel sinter filter, ~2m TPU cable	
Adjustment	At 23 °C and 10, 35, 80 %rh	
Accuracy	±0.8 %rh / ±0.1 K / Response time τ 63: <20 s	
Probe length	280 mm	500 mm
Handle color	Anthracite	
Steel sinter filter	ET-Z10 included	
Weight	Approx. 200 g	

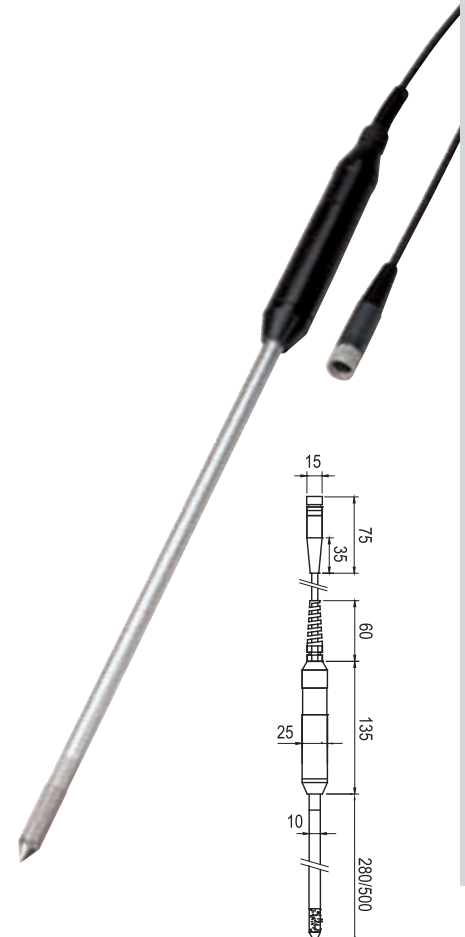

SWORD PROBES 22 x 4 mm

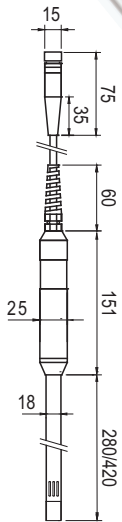
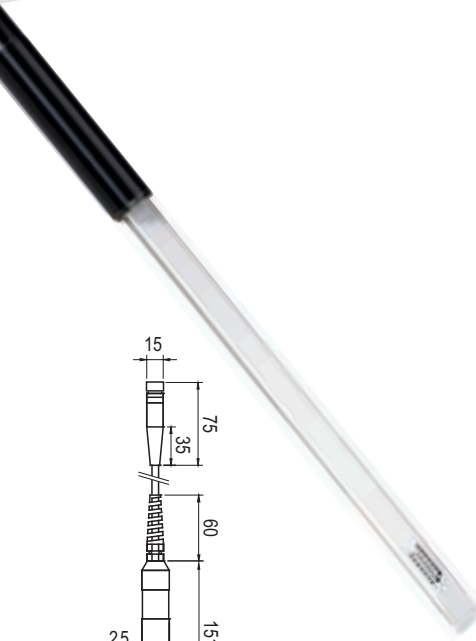

Applications

For measurement in stacks of paper, cardboard, textiles, etc.

Use

Handheld instruments and data loggers

Highlights

- Measures relative humidity, temperature and dew/frost point
- Saves up to 2,000 measurement pairs (requires HW4 software)
- Range of application: 0...100 %rh / -40...85 °C
- UART interface and freely scalable analog signals 0...1 V
- Standard scaling 0...1 V = 0...100 %rh / -40...60 °C
- Probe with 'Standard' adjustment profile, factory adjustment certificate

Order code	HC2-HS28	HC2-HS42
Type	Sword probe with air slots, ~2m TPU cable	
Adjustment	At 23 °C and 10, 35, 80 %rh	
Accuracy	±0.8 %rh / ±0.1 K / Response time τ_{63} : <15 s	
Probe length	280 mm	420 mm
Handle color	Anthracite	
Weight	Approx. 240 g	Approx. 300 g

INDUSTRIAL PROBES 15 mm

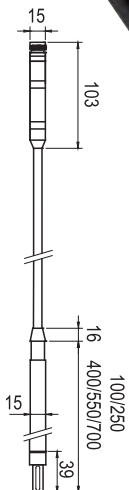

Applications

Measurements in all environments up to 200 °C such as industrial dryers and climatic chambers

Use

Transmitters, handheld devices, data loggers, OEM products

Highlights

- Measures relative humidity, temperature and dew/frost point
- Use as a reference for system validation
- Saves up to 2,000 measurement pairs (requires HW4 software)
- Range of application 0...100 %rh / -100...200 °C
- UART interface and freely scalable analog signals 0...1 V
- Standard scaling 0...1 V = 0...100 %rh / -40...60 °C
- Probe with 'Standard' adjustment profile, factory adjustment certificate

Order code	HC2-IC1xx*	HC2-IC3xx*	HC2-IC4xx*	HC2-IC5xx*	HC2-IC7xx*
	*xx = cable length in m (02, 05, etc), 80g per additional metre				
Type	PPS industrial probe with ROTRONIC connector				
Adjustment	At 23 °C and 10, 35, 80 %rh				
Accuracy	±0.8 %rh / ±0.1 K / Response time τ_{63} : without filter < 15 s				
Probe length	100 mm	250 mm	400 mm	550 mm	700 mm
Filter carrier	NSP-ME (order filter separately, see pages 99-100)				
Weight	Approx. 230 g	Approx. 260 g	Approx. 290 g	Approx. 230 g	Approx. 250g

INDUSTRIAL PROBES 15 / 25 mm

Applications

Measurements in all types of industrial processes and environments up to 200 °C

Use

Handheld devices, data loggers, transmitters, OEM products

Highlights

- Measures relative humidity, temperature and dew/frost point
- Use as reference for system validation
- Saves up to 2,000 measurement pairs (optional, requires HW4 software)
- Range of application 0...100 %rh / -100...200 °C
- UART interface and freely scalable analog signals 0...1 V
- Standard scaling 0...1 V = 0...100 %rh / -40...60 °C
- Probe with 'Standard' adjustment profile, factory adjustment certificate

Order code	HC2-IC3xx*-A	HC2-IC4xx*-A	HC2-IC5xx*-A	HC2-IC7xx*-A
	*xx = cable length in m (02, 05) 80 g per m cable length			
Type	PPS industrial probe with ROTRONIC connector			
Adjustment	At 23 °C and 10, 35, 80 %rh			
Accuracy	±0.8 %rh / ±0.1 K / Response time τ 63: without filter <15 s			
Probe length	250 mm	400 mm	550 mm	700 mm
Filter carrier	NSP-ME (order filter separately, see pages 99-100)			
Weight	Approx. 290 g	Approx. 320 g	Approx. 350 g	Approx. 380 g



INDUSTRIAL PROBES 15 mm

Applications

Measurements in all types of industrial processes to 200 °C

Use

Handheld devices, data loggers, transmitters, OEM products

Highlights

- Measures relative humidity, temperature and dew/frost point
- Use as a reference for system validation
- Saves up to 2,000 measurement pairs (optional, requires HW4 software)
- Range of application 0...100 %rh / -100...200 °C
- UART interface and freely scalable analog signals 0...1 V
- Standard scaling 0...1 V = 0...100 %rh / -40...60 °C
- Probe material: DIN 1.4305 or AISI 302 / AFNOR Z10 CNF 18-9
- Probe with 'Standard' adjustment profile, factory adjustment certificate

Order code	HC2-IM1xx*	HC2-IM3xx*	HC2-IM4xx*	HC2-IM5xx*
	*xx = cable length in m (02, 05) 80 g per m cable length			
Type	Industrial probe of chrome nickel steel with ROTRONIC connector			
Adjustment	At 23 °C and 10, 35, 80 %rh			
Accuracy	±0.8 %rh / ±0.1 K / Response time τ 63: without filter <15 s			
Probe length	120 mm	280 mm	430 mm	580 mm
Filter carrier	SP-MSB15 (order filter separately, see pages 99-100)			
Weight	Approx. 260 g	Approx. 400 g	Approx. 540 g	Approx. 680 g

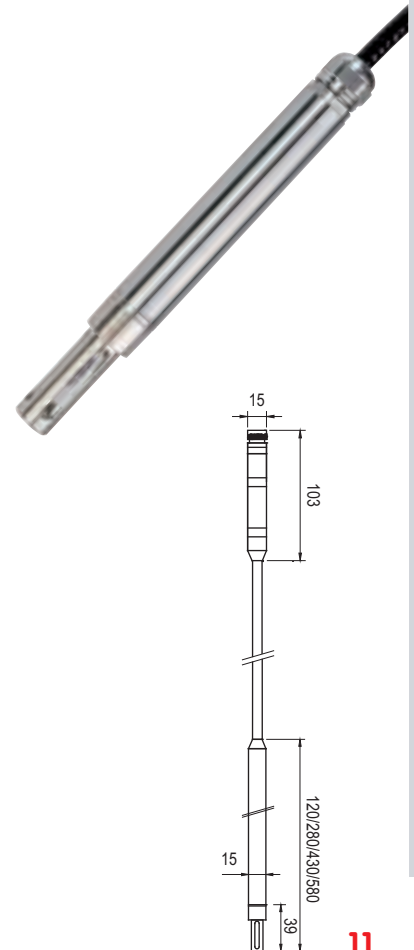

SCREW-IN PROBES



Applications

Measurements in all types of industrial processes up to 100 bar and to 200 °C

Use

Transmitters, OEM products

Highlights

- Measures relative humidity, temperature and dew/frost point
- Screw-in probe with ROTRONIC connector, steel housing
- Suitable for pressures up to 400bar (5800 psi)
- Saves up to 2,000 measurement pairs (optional, requires HW4 software)
- Range of application 0...100 %rh / -100...200 °C / 0...400 bar / 0...5800 PSI
- UART interface and freely scalable analog signals 0...1 V
- Standard scaling 0...1 V = 0...100 %rh / -40...60 °C
- Probe material: DIN 1.4305 or AISI 302 / AFNOR Z10 CNF 18-9
- Probe with 'Standard' adjustment profile, factory adjustment certificate

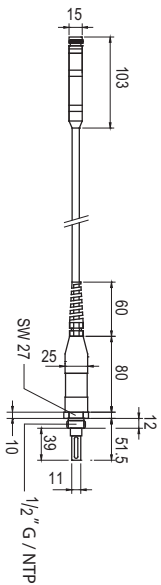

Order code	HC2-IE1xx*	HC2-IE3xx*
	*xx = cable length in m (02, 05) 80 g per m cable length	
Type	1/2" G with ROTRONIC connector	1/2" NPT with ROTRONIC connector
Adjustment	At 23 °C and 10, 35, 80 %rh	
Accuracy	±0.8 %rh / ±0.1 K / Response time τ 63: without filter <15 s	
Filter carrier	SP-MSB15 (order filter separately, see pages 99-100)	
Weight	Approx. 290 g	

PROBES

Detailed specifications	
Power supply / Connections	
Supply voltage (VDD)	HC2-IC, HC2-IM and HC2-IE: 3.3 V ± 0.1 V, other types: 3.2 ...5.0 VDC ±0%
Nominal current consumption	<4,0 mA at VDD = 3,3 VDC
Humidity measurement	
Sensor	ROTRONIC Hygromer® IN-1 (exception HC2-S3, Hygromer® V-1)
Measurement range	0...100 %rh
Accuracy at 23 °C	±0.8 %rh
Repeatability	0.3 %rh
Long term stability	<1 %rh/year
Temperature measurement	
Sensor	Pt100 1/3 Class B
Measurement range	-100...200 °C
Accuracy at 23 °C	±0.1 K
Repeatability	0.05 °C
Long term stability	<1 °C/year
Response time	4 sec for 63 % of the change from 23 to 80 °C (1 m/sec air flow at sensor)
Calculated parameters	
Psychrometric calculations	Dew point or frost point
Start-up time / Refresh rate	<2 s / <0.9 s (main clock 5 MHz)
Configurable analogue outputs	
Output 1 standard	Relative humidity; 0...100 %rh = 0...1 V
Output 2 standard	Temperature -40...60 °C = 0...1 V
Scale limits	-999.99...+9999.99 units, user configurable with HW4 software
Digital interface (service connector)	
Type of interface	UART (universal asynchronous receiver transmitter)
Maximum length service cable	5 m (16.4 ft) without signal amplifier
General specifications	
Housing material	Polycarbonate / ABS
Connector material	Anodized anticorodal aluminium
Filter material	Depending on probe / filter type
Protection	IP 65
CE/EMC compatibility	CE-compliant, 2007/108/EC EN 61000-6-1: 2001, EN 61000-6-2: 2005 EN 61000-6-3: 2005, EN 61000-6-4: 2001 + A11
Solder	Lead-free (RoHS-compliant)
FDA/GAMP compatibility	FDA 21 CFR Part 11 / GAMP 4
Electronics operating range	-50...100 °C / 0...100 %rh, non-condensing
Max. air velocity at probe	40 m/s (7,870 ft/min)

PROBES FOR SPECIAL APPLICATIONS

We have probes with optimised sensors and/or filters that offer improved resistance to pollutants and other harmful substances in various special applications. They can be ordered with the order numbers given below and connected with a standard handheld, data logger or transmitters

For all special applications involving pollutants and other harmful substances:

To attain optimum accuracy, probes should be calibrated at more regular intervals than usual and adjusted if necessary. ROTRONIC does not keep stock of special probes. It is the customer's responsibility to keep spare probe for critical application scenarios.

Hygromer HH sensor

The HH sensors were specifically developed for use in sterilization processes involving Hydrogen Peroxide (H₂O₂). H₂O₂ is very aggressive and will destroy every sensor sooner or later. The HH sensors are manufactured using a specific formula so that they can resist H₂O₂ and other harmful substances or process chemicals for a longer period of time.

Hygromer V-1 sensor

The Hygromer V-1 sensors are based on the tried-and-tested IN-1 sensor. They were developed for applications with long periods of condensation as often occur in, for example, agricultural meteorology. Robust in construction, they have excellent long term stability and resistance to thawing. At <20 seconds, their response times are still very short. This also establishes the sensors for use in drying processes using alcohol in air. Such processes are often used in the food and pharmaceutical industries.

Hygromer M1R

The Hygromer M1R sensors are highly suitable for applications with rapid changes in climatic conditions as typically occur in, for example, high altitude meteorology.

They are used in weather balloons, which pass through immense differences in altitude with corresponding climatic changes in a very short time. The sensor has extremely short response times of <3 seconds and still reacts quickly at low temperatures. It may be used in temperatures ranging from -80...140 °C.

It is not possible to specify lifetimes for the sensors because they depend very fundamentally on the particular application. Depending on the humidity, temperature, pollutants/harmful substances involved and the number of cycles, they can vary immensely.

Order code	Application / Harmful substance / Problem	Contains
HC2-S-HH	Disinfection / Sterilization with H ₂ O ₂	HygroClip2 with Hygromer HH
HC2-IC102-HH	Applications with ozone	Industrial HygroClip2 (2 m cable) with Hygromer HH
HC2-S-V1	Agricultural meteorology / Drying with alcohol	HygroClip2 with Hygromer V1
HC-IC102-V1	Climatic chambers to 200 °C	HygroClip2 with Hygromer V1
HC2-S-M1R	Weather balloons: cold, rapid changes in conditions	HygroClip2 with ultra-fast Hygromer M1R



V-1 sensor



HH1-SK sensor



M3-R sensor